



Project _____
 Item No. _____
 Model No. _____
 Quantity _____

CSI No. 114000

REACH-IN DUAL TEMP - THREE SECTION



RF-75-SS-3S-D
 75" Wide, S/S Exterior & Interior

MODEL GUIDE

Model Number	Description
<input type="checkbox"/> RF-75-SS-3S-D	75" Wide, S/S Exterior & Interior
<input type="checkbox"/> RF-75-SA-3S-D	75" Wide, S/S Exterior, Aluminum Interior
<input type="checkbox"/> RF-90-SS-3S-D	90" Wide, S/S Exterior & Interior
<input type="checkbox"/> RF-90-SA-3S-D	90" Wide, S/S Exterior, Aluminum Interior
Options	Model Number Modification
<input type="checkbox"/> Remote Refrigeration	Add suffix "X" to model number
<input type="checkbox"/> Half Doors	Change "3S" to "6S"
<input type="checkbox"/> Pass-Thru	Add prefix "PT" to model number
<input type="checkbox"/> Narrow Depth	Change suffix "D" to "N"
<input type="checkbox"/> Glass Door	Change "3S" to "3G"

AGENCY APPROVALS:



Intertek



Intertek

STANDARD FEATURES:

Construction/Cabinet

- Exterior sides – heavy gauge stainless steel
- Exterior back and bottom – heavy gauge galvanized
- Stainless steel compressor housing
- Stainless steel front, door, rails and top-mount
- Heavy-duty 6" adjustable stainless steel legs
- Cabinet body is foamed-in-place polyurethane insulation
- Fully covered interior with welded radius corners for easy cleaning
- Interior LED lighting
- Stainless steel shelf clips and shelf standards
- Four adjustable chrome plated wire shelves per section

Doors

- Self-closing, lift off door hinges with stay-open feature at 120°
- Standard left door hinged left, center and right door hinged right (other configurations available)
- Full-length, one-piece recessed Unigrip™ door handle (solid door models)
- Heavy-duty, built-in security cylinder door lock (solid door models)
- Energy saving condensate heater around door opening
- Snap-in magnetic door gasket
- Impact-resistant PVC breaker strip

Refrigeration Package

- Expansion valve refrigeration system for superior recovery and temperature pulldown
- Pressure control – prevents compressor burnout in case of refrigerant loss
- Top-mounted compressor
- R-449a, low GWP refrigerant for superior temperature recovery and pulldown
- Hot gas condensate evaporator quickly dissipates condensation using zero additional energy
- Receiver tank and service valves – allows reuse of refrigerant and enables rapid pulldown during times of peak demand
- Integrated sight glass – allows technicians to easily detect leaks or moisture without tools

Control Systems & Warranty Coverage

- Dual digital temperature controls – easily adjust refrigerator setpoint between 35-40°F; freezer setpoint between -5 to +5°F
- Master power switch
- One 9 foot electrical cord (solid door models only)
- Warranty: 5 year compressor, 5 year parts, 1 year labor

OPTIONS & ACCESSORIES:

- Stainless steel back ___ top___ bottom___ (specify all that apply)
- Drawers in lieu of lower half door (requires half-door option)
- Additional chrome wire shelves (specify quantity) _____
- Stainless steel wire shelves in lieu of chrome shelves
- Tray slides (specify quantity)
 "L" Type ___ Universal slides ___ "R" Type ___
- Digital temperature control & solenoid for remote models
- Stainless steel curb base (specify 4" or 6" high)
- Temperature alarm
- 6" front locking casters in lieu of legs (no charge)
- 4" front locking casters in lieu of legs
- 6" seismic legs
- Correctional facilities package
- Top-mounted evaporator coil (std. depth units only)
- Water-cooled condensing unit
- 5" high top-mount (remote compressor models)



REACH-IN DUAL TEMP - THREE SECTION

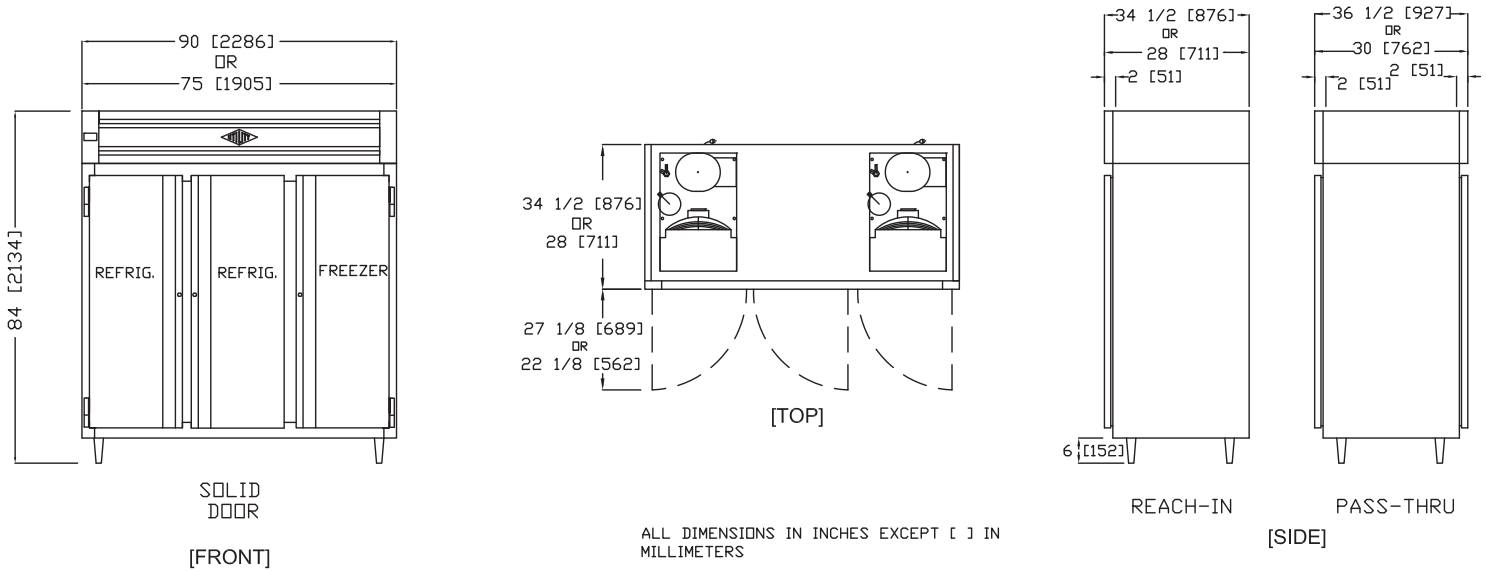

PRODUCT DATA	RF-75 Series Standard Depth	RF-75 Series Narrow Depth	RF-90 Series Standard Depth	RF-90 Series Narrow Depth
KEY DIMENSIONS				
Width (overall)	75.0"	75.0"	90.0"	90.0"
Depth (overall)	34.5"	28.0"	34.5"	28.0"
Depth Pass-Thru Models (overall)	36.5"	30.0"	36.5"	30.0"
Height (overall inc. legs)	84.0"	84.0"	84.0"	84.0"
Door Opening (net width)	18.25"	18.25"	23.25"	23.25"
Door Opening (net height)	57.25"	57.25"	57.25"	57.25"
Half Door Opening (net ht.)	26.75"	26.75"	26.75"	26.75"
CAPACITY				
Capacity (cu.ft.)	62	47	76	58
Number of Shelves	12	12	12	12
Shelf Area (sq. ft., including bottom)	61	46	75	56
ELECTRICAL				
Voltage (two dedicated circuits required)	115	115	115	115
Amperage (self-contained; refrigerator compartment)	9.8	9.8	9.1	10.0
Amperage (self-contained; freezer compartment)	7.5	7.5	8.4	7.6
Amperage (remote; refrigerator compartment)	6.4	6.4	6.6	6.6
Amperage (remote; freezer compartment)	8.3	8.3	9.5	8.4
BTU requirement*, remote (refrigerator compartment)	2590	2496	3190	2696
BTU requirement*, remote (freezer compartment)	1440	1395	1575	1495
NEMA Plug Config (self-contained only; refrigerator compartment)	5-15P	5-15P	5-15P	5-15P
NEMA Plug Config (self-contained only; freezer compartment)	5-15P	5-15P	5-15P	5-15P
Horsepower (self-contained; refrigerator compartment)	1/3	1/3	1/3	1/3
Horsepower (self-contained; freezer compartment)	1/3	1/3	1/3	1/3
SHIPPING				
Ship Weight (lbs.)	930	870	1120	1045
Ship Volume, Standard Depth (cu.ft.)	196	171	232	203
Crated Dimensions (87" H)	81" W x 48" D	81" W x 48" D	96" W x 48" D	96" W x 48" D

*90°F ambient, 20°F evaporator (refrigerator) or -15°F evaporator (freezer), 20" max. line length.

Data is for standard models; options may change specifications.

UTILITY REFRIGERATOR

12160 Sherman Way • North Hollywood, CA 91605

Telephone: (818) 764-6200 • Fax: (818) 764-6211

www.utilityrefrigerator.com

DUE TO CONTINUOUS PRODUCT IMPROVEMENTS, SPECIFICATIONS ARE SUBJECT TO CHANGE WITHOUT NOTICE.

©/™/® Utility Refrigerator



WARNING - This product can expose you to chemicals including Di(2-ethylhexyl)phthalate (DEHP), which is [are] known to the State of California to cause cancer and birth defects or other reproductive harm. For more information go to www.P65Warnings.ca.gov