



Project \_\_\_\_\_  
 Item No. \_\_\_\_\_  
 Model No. \_\_\_\_\_  
 Quantity \_\_\_\_\_

CSI No. 114000

# COUNTER HEIGHT REFRIGERATOR - TWO SECTION



CHR-50-2S-D-EM  
 68" Overall Width, Two Doors  
 (shown with optional stainless steel flat top)

## MODEL GUIDE

Model Number	Description
<input type="checkbox"/> CHR-50-2S-D-EM	68" Overall Width, Two Doors
<input type="checkbox"/> CHR-60-2S-D-EM	78" Overall Width, Two Doors
Options	Model Number Modification
<input type="checkbox"/> Remote Refrigeration	Delete suffix "EM" from model number
<input type="checkbox"/> Pass-Thru	Add prefix "PT" to model number
<input type="checkbox"/> Narrow Depth	Change "D" to "N"

## AGENCY APPROVALS:



Intertek



Intertek

## STANDARD FEATURES:

### Construction/Cabinet

- Exterior front and sides – heavy gauge stainless steel
- Exterior back and bottom – heavy gauge galvanized
- Stainless steel compressor housing
- Stainless steel front, door, end mount, and interior
- Heavy-duty 6" adjustable stainless steel legs
- Cabinet body is foamed-in-place minimum 2-1/2" thick polyurethane insulation
- Fully covered interior with welded radius corners for easy cleaning
- Optional drawers hold two 12" x 20" pans or fractional pans (pans by others)
- Rugged drawer construction
- Welded stainless steel door handle or drawer pull
- Compressor housing located on left side (optional on right side)
- Stainless steel shelf clips and shelf standards
- One adjustable chrome plated wire shelf per section

### Doors

- Self-closing, lift off door hinges with stay-open feature at 120°
- Standard left door hinged left, right door hinged right (other configurations available)
- Energy saving condensate heater around door opening
- Snap-in magnetic door gasket
- Impact-resistant PVC breaker strip

### Refrigeration Package

- Slideout condensing unit - enables fast and easy service
- Expansion valve refrigeration system for superior recovery and temperature pulldown
- Low Pressure control – prevents compressor burnout in case of refrigerant loss
- R-513a, low GWP refrigerant for superior temperature recovery and pulldown
- Hot gas condensate evaporator quickly dissipates condensation using zero additional energy
- Receiver tank and service valves – allows reuse of refrigerant and enables rapid pulldown during times of peak demand
- Integrated sight glass – allows technicians to easily detect leaks or moisture without tools

### Control Systems & Warranty Coverage

- Digital temperature control – easily adjust setpoint between 35-40°F
- Master power switch
- One 9 foot electrical cord
- Warranty: 5 year compressor, 5 year parts, 1 year labor

## OPTIONS & ACCESSORIES:

- Stainless steel top (specify flat or marine edge type)
- Stainless steel back \_\_\_ bottom \_\_\_ (specify either or both)
- Additional chrome wire shelves (specify quantity) \_\_\_\_\_
- Stainless steel wire shelves in lieu of chrome shelves
- Tray slides (specify quantity)  
     "L" Type \_\_\_ Universal slides \_\_\_ "R" Type \_\_\_
- Digital temperature control & solenoid for remote models
- Refrigerant options for remote models-please specify refrigerant type
- Stainless steel curb base (specify 4" or 6" high)
- Temperature alarm
- 6" front locking casters in lieu of legs (no charge)
- 6" seismic legs
- 5" front locking casters
- 4" front locking casters
- 2 or 3 drawers in lieu of door (std depth 30", 60", or 90" sections only)
- Correctional facilities package
- Water-cooled condensing unit
- Interior LED lighting
- Marine secure latch
- ADA Height – stainless steel sub top changes overall height to 31.5" (requires 4" high casters)
- Glass doors



# COUNTER HEIGHT REFRIGERATOR - TWO SECTION

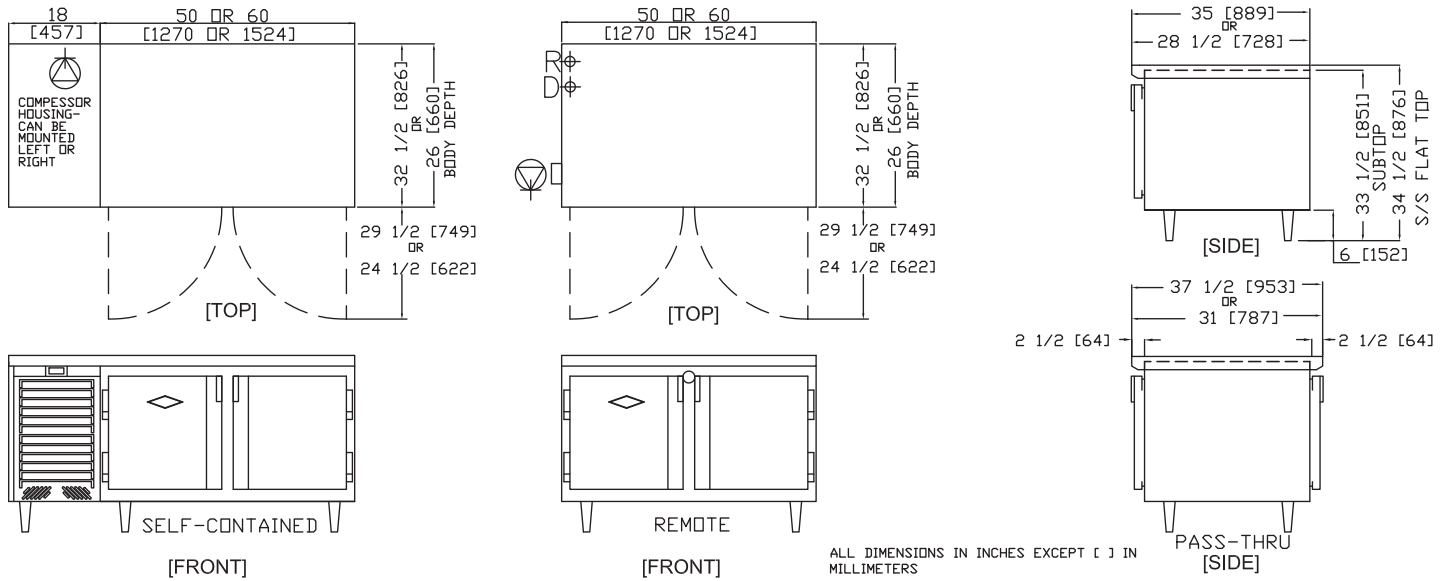

PRODUCT DATA	CHR-50 Standard Depth	CHR-50 Narrow Depth	CHR-60 Standard Depth	CHR-60 Narrow Depth
<b>KEY DIMENSIONS</b>				
Width, Self-Contained (overall)	68.0"	68.0"	78.0"	78.0"
Width, Remote (overall)	50.0"	50.0"	60.0"	60.0"
Depth (overall)	34.5"	28.0"	34.5"	28.0"
Depth Pass-Thru Models (overall)	36.5"	30.0"	36.5"	30.0"
Height (overall inc. legs; w/ subtop)	33.5"	33.5"	33.5"	33.5"
Height (overall inc. legs; w/ optional s/s finished top)	34.5"	34.5"	34.5"	34.5"
<b>CAPACITY</b>				
Capacity (cu.ft.)	16	12	19	15
<b>ELECTRICAL</b>				
Voltage (dedicated circuit required)	115	115	115	115
Amperage (self-contained)	5.5	5.5	5.7	5.7
Amperage (remote refrigeration)	4.2	4.2	4.4	4.4
BTU requirement*, remote	1345	1274	1471	1400
NEMA Plug Configuration (self-contained only)	5-15P	5-15P	5-15P	5-15P
Horsepower (self-contained)	1/4	1/4	1/4	1/4
<b>SHIPPING</b>				
ShipWeight, Self-Contained (lbs.)	550	500	610	560
ShipWeight, Remote (lbs.)	320	300	400	380
Ship Volume, Self-Contained (cu.ft.)	80	70	91	80
Ship Volume, Remote (cu.ft.)	61	53	72	63
CratedDimensions, Self-Contained (39" H)	74"W x 48"D	74"W x 42"D	84"W x 48"D	84"W x 42"D
CratedDimensions, Remote (39" H)	56"W x 48"D	56"W x 42"D	66"W x 48"D	66"W x 42"D

\*90°F ambient, 20°F evaporator, 20' max. line length.

Data is for standard models: options may change specifications.

## UTILITY REFRIGERATOR

12160 Sherman Way • North Hollywood, CA 91605

Telephone: (818) 764-6200 • Fax: (818) 764-6211

[www.utilityrefrigerator.com](http://www.utilityrefrigerator.com)

*DUE TO CONTINUOUS PRODUCT IMPROVEMENTS, SPECIFICATIONS ARE SUBJECT TO CHANGE WITHOUT NOTICE.*

©/™/® Utility Refrigerator



WARNING - This product can expose you to chemicals including Di(2-ethylhexyl)phthalate (DEHP), which is [are] known to the State of California to cause cancer and birth defects or other reproductive harm. For more information go to [www.P65Warnings.ca.gov](http://www.P65Warnings.ca.gov)

UR-CHR2 | MU