

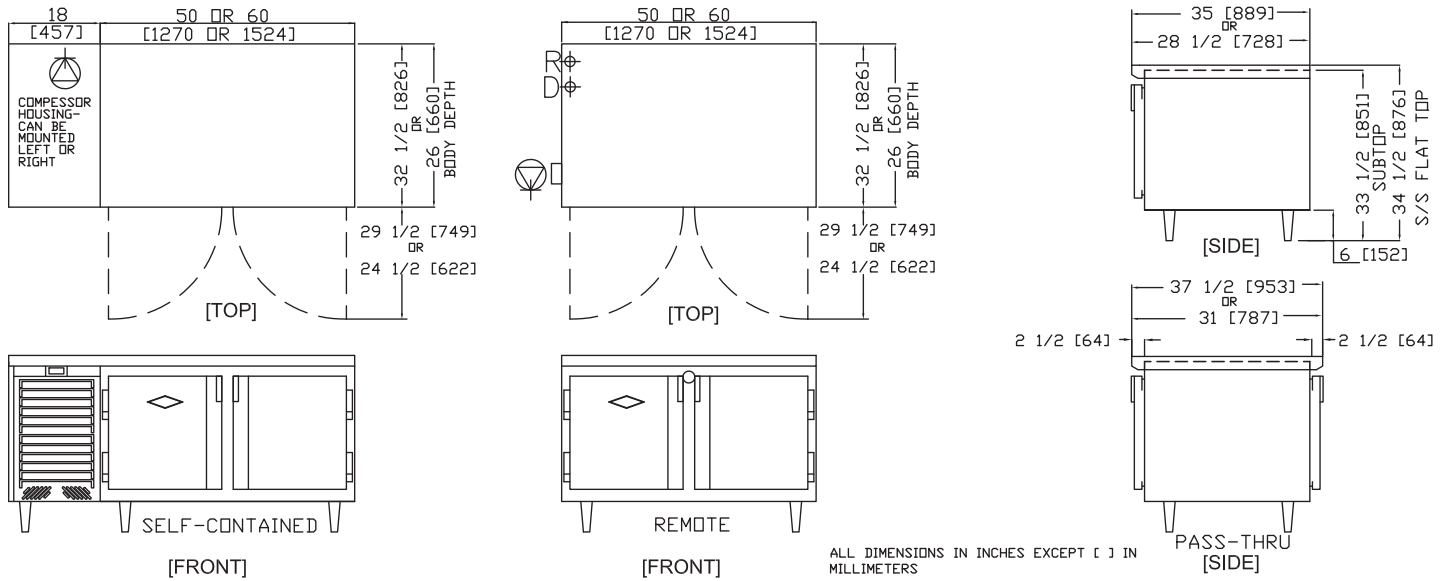

COUNTER HEIGHT FREEZER - TWO SECTION



PRODUCT DATA	CHF-50 Standard Depth	CHF-50 Narrow Depth	CHF-60 Standard Depth	CHF-60 Narrow Depth
KEY DIMENSIONS				
Width, Self-Contained (overall)	68.0"	68.0"	78.0"	78.0"
Width, Remote (overall)	50.0"	50.0"	60.0"	60.0"
Depth (overall)	34.5"	28.0"	34.5"	28.0"
Depth Pass-Thru Models (overall)	36.5"	30.0"	36.5"	30.0"
Height (overall inc. legs; w/ subtop)	33.5"	33.5"	33.5"	33.5"
Height (overall inc. legs; w/ optional s/s finished top)	34.5"	34.5"	34.5"	34.5"
CAPACITY				
Capacity (cu.ft.)	16	12	19	15
ELECTRICAL				
Voltage (dedicated circuit required)	115	115	115	115
Amperage (self-contained)	7.6	7.6	8.6	8.6
Amperage (remote refrigeration)	7.5	7.5	8.8	8.8
BTU requirement*, remote	1640	1543	2132	2039
NEMA Plug Configuration (self-contained only)	5-15P	5-15P	5-15P	5-15P
Horsepower (self-contained)	1/2	1/2	1/2	1/2
SHIPPING				
ShipWeight, Self-Contained (lbs.)	550	500	610	560
ShipWeight, Remote (lbs.)	320	300	400	380
Ship Volume, Self-Contained (cu. ft.)	80	70	91	80
Ship Volume, Remote (cu. ft.)	61	53	72	63
CratedDimensions, Self-Contained (39" H)	74" W x 48" D	74" W x 42" D	84" W x 48" D	84" W x 42" D
CratedDimensions, Remote (39" H)	56" W x 48" D	56" W x 42" D	66" W x 48" D	66" W x 42" D

*90°F ambient, -15°F evaporator, 20' max. line length.

Data is for standard models: options may change specifications.

UTILITY REFRIGERATOR

12160 Sherman Way • North Hollywood, CA 91605

Telephone: (818) 764-6200 • Fax: (818) 764-6211

www.utilityrefrigerator.com

DUE TO CONTINUOUS PRODUCT IMPROVEMENTS, SPECIFICATIONS ARE SUBJECT TO CHANGE WITHOUT NOTICE.

©/™/® Utility Refrigerator



WARNING - This product can expose you to chemicals including Di(2-ethylhexyl)phthalate (DEHP), which is [are] known to the State of California to cause cancer and birth defects or other reproductive harm. For more information go to www.P65Warnings.ca.gov

UR-CHF2 | MU